



BMW M50/52 ITB Kit

Assembly instructions

sales@racehead.com.au

Xinyi Dist, Taipei, Taiwan +886 975 292 194

Taren Pt, NSW, Australia +61 408 608 318

Notes:

Thank you for choosing an RHD ITB Kit. All RHD parts and products are designed for performance and racing purposes, what you do with your vehicle is your responsibility and no liability will be taken by RHD Engineering for your actions.

This kit is designed to work with the standard ECU and does work well straight off installation. However lots of details do need special attention. Many tuning companies offer services for tuning the factory DME this is recommended at the very least for optimising the performance. Installing a stand-alone ECU configured with Alpha-N will always bring the best results. Do NOT try to use MAP as the only signal for tuning ITB systems. Most quality ECU brands will have no problem running pure Alpha-N. However some brands may struggle with resolution so a combination of TPS and MAP is needed at the very least. We recommend EcuMaster as an affordable high quality ecu and we can offer support and tune files for all our ITB kits.

The throttle bodies are made to very tight tolerances and have been PRE-SET for normal engine running temperature. They may feel a little bit tight or sticky when fully closed. This is perfectly normal DO NOT try to adjust them.

To install and set up this kit you will need a weber/ITB synchronizing tool, a good understanding of mechanical devices and the appropriate mechanics tools. Parts; you will need some 8mm vacuum hose and pod filter.

Please check all the parts are included and contact us immediately if you have any pieces missing.

Manifold	3 pcs
45mm ITBs	3 pcs
Trumpets	6 sets
Trumpet spacers	6 pcs
50mmx2mm O rings	12 pcs
Linkage brackets	2 pcs
M5 drop link set	1 set (2 rod ends, 2 nuts, 1 link, 2 cap screws)
Spring balance adjuster	2 pcs
Flat arm coupler	1 pc
TPS fixing plate and screws	1 pc
Linkage mechanism	1 pc (shaft, return spring, bracket and cable quadrant)
ITB master lever set	1 set (Idle stop, screw, secondary spring)
Short lever	1 pc
M5 x 12 Hex bolts	2 pcs
Fuel rail spacers and bolts	2 pcs each
9 port vacuum block	1 pc
8mm x 1/8 bsp hose tails	6 pcs
8mm x 1/4 bsp hose tail	6 pcs
12mm x 1/4 bsp hose tail	1 pc
Tee fitting 1/4 bsp MMF	1 pc
6mm x 1/8 bsp hose tail	1pc
4mm x 1/8 bsp hose tail	1 pc
16mm x 3/8 bsp hose tail	1 pc
ICV hose patch fitting	1 pc
M8 x 25 cap screws	12 pcs
M6 x 20 cap screws	12 pcs
M6 x 16 cap screws	12 pcs
M5 x 16 cap screws	10 pcs
Plenum backing plate	1 pc
Plenum	1 pc

Assembly Procedure:

NEW!... We are working on a series of Youtube installation videos, they will be available very soon. Keep an eye on our website under downloads and FAQ pages www.racehead.com.au

NOTE: Current version kits have a fixed TPS adapter position however the screws that attach the actual TPS still have some movement. This can be used to slightly adjust the position if needed. Output voltage can be measured between pins 1&2 and should be exactly 0.5v when the throttles are fully closed. Test this with the ignition on and the TPS plugged in before you bolt the throttle to the manifold. This is only important when using the factory ECU.

Assemble the throttles as per the following pictures. Make sure the throttle with the master lever is fully closed with the idle stop screw just touching the little round stop. Adjust the balance adjuster screws so they protrude about 2mm towards the J spring, leave the balance adjusters only slightly tight on the shafts for the moment.. Before installing the manifolds fit all the little brass pipe fittings and T fitting to the underside following the diagram. Install the manifolds fuel rail with injectors first then attach the throttles. Make sure the little coupling tabs are wedged firmly between the adjuster screw and the J spring (NOT in the centre of the J spring loop) Install the linkage mounting bracket on the centre throttle. Loosen the adjusters and push on all the throttles with your finger to make sure they are all fully closed before you tighten the adjusters firmly. Next install the linkage and idle circuit parts and hoses. Install the spacers using the shorter m6 x 16 cap screws. No backing plate, trumpets or plenum for the moment.

Now you can start the engine and synchronization the throttles, you might need to fully or partially block the inlet of the ICV for it to rum and idle. Use the outer throttle cable adjuster to tension the cable until the engine is running at least 1000-1200rpm. Allow the engine to warm up to normal running temperature before synchronizing.

Adjusting the balance is EXTREAMLY sensitive and near perfect synchronization is essential for smooth idle and good light throttle driving. To do this you MUST use a FLOW synchronizer such as the one pictured below. Measuring vacuum is not a good indication of flow.



Press the synchronizer into each spacer. Adjust the balance couplings until the flow into each runner is exactly the same. Measure cylinders 3&4 first then adjust the front pair and rear pair to match the center ones using the small adjusters on the couplings. Adjust the cable back down so the throttles are fully closed again.

Plenum:

Remove the spacers then build an assembly of the backing plate spacers and trumpets leaving all the screws loose. Bolt the plenum to the backing plate and fully tighten. You can use RTV type sealant or make a compressible gasket between the backing plate and plenum, not essential using a stand-alone ecu but recommended when using the OEM ECU. Install the whole assembly back onto the engine again making sure the screws between the trumpets and spacers are loose. Install all the screws before any of them are tightened. Tighten all the screws starting from the throttles, tighten the spacers onto the trumpets last

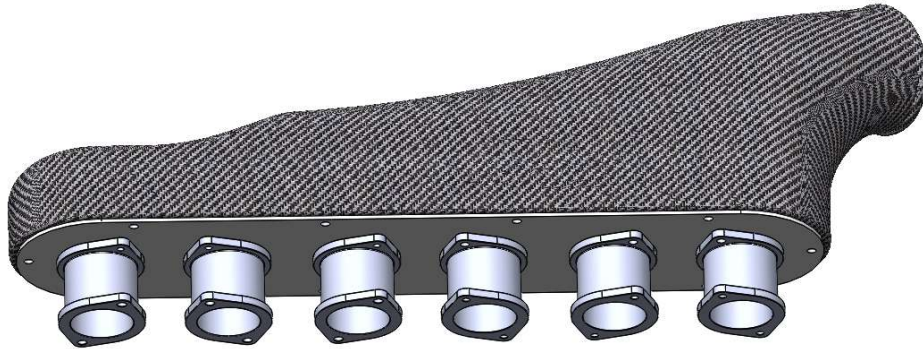

Assembly Notes:

Study the following drawings very closely they show the exact placement of all the fittings and linkage parts

The small return spring on the master ITB is only intended as a SECONDARY spring to ensure the throttles close should any linkage part becomes loose or disconnected. A second main return spring is included on the linkage mechanism and can be preloaded up to a maximum of 180 degrees to add the desired amount of pedal resistance.

For nice progressive throttle action keep the drop link as short as possible. However if your ITB does not reach full throttle when the pedal is fully depressed then adjusting the drop link to a longer length and resetting the cable slack will alter the mechanism gain and will enable the throttle to reach full open.

Make sure the linkage moves freely and smoothly without any binding. Light lubricant such as WD40 on moving parts is good. It is important the ITB linkage doesn't reach full throttle when there is still lots of extra travel on the pedal this will over load your cable and linkage resulting in possible damage or premature cable failure.

You will need to drill some holes in the plenum and /or backing plate for the Air Temperature Sensor and also the patch fitting for the Idle Control Valve. It is important that the ICV draws metered air AFTER the MAF sensor. For stand alone ecu the ICV inlet is not important.

Crank case breather can also be plumbed into the plenum or alternatively run to a vented catch can mounted in the engine bay

Brakes:

For correct brake booster operation you will need to attach the vacuum hose to the T fitting provided on the manifold. The booster will work exactly as it did before running from just 1 cylinder. The vacuum from 1 cylinder is much stronger than the signal from the vacuum accumulator block! It is essential that the small plastic 1-way valve fitted to the factory booster line is maintained.

DO NOT connect the booster line to the vacuum block!

Happy motoring ☺

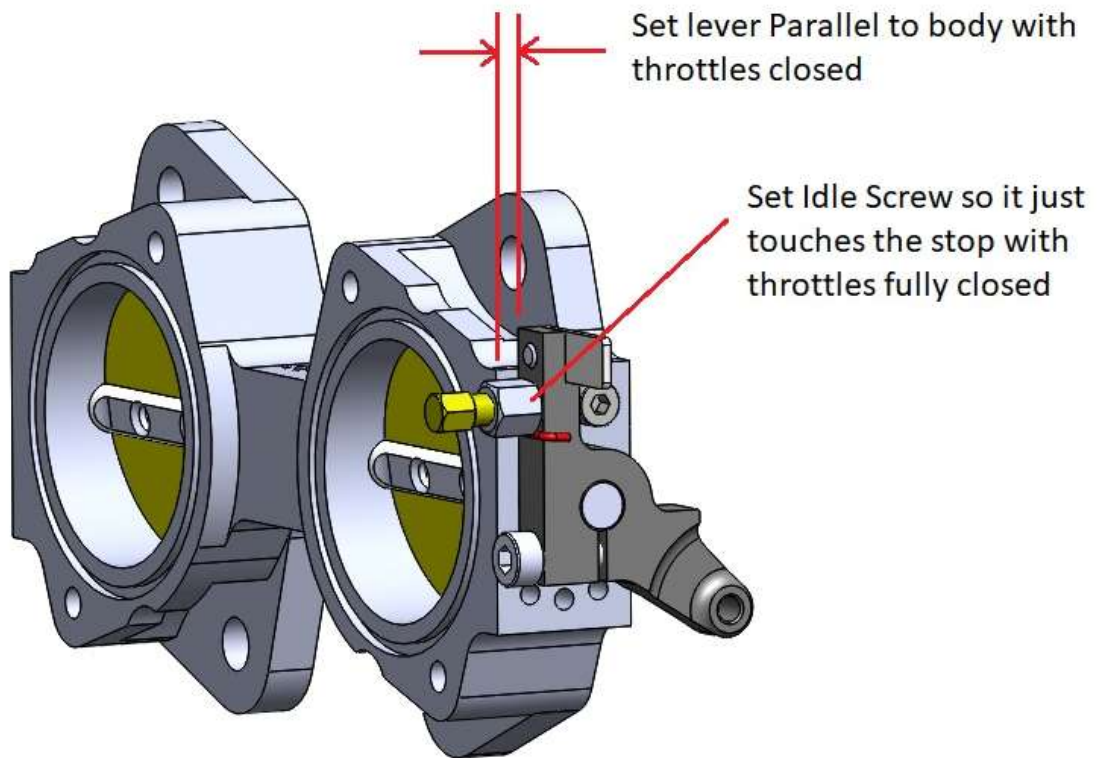
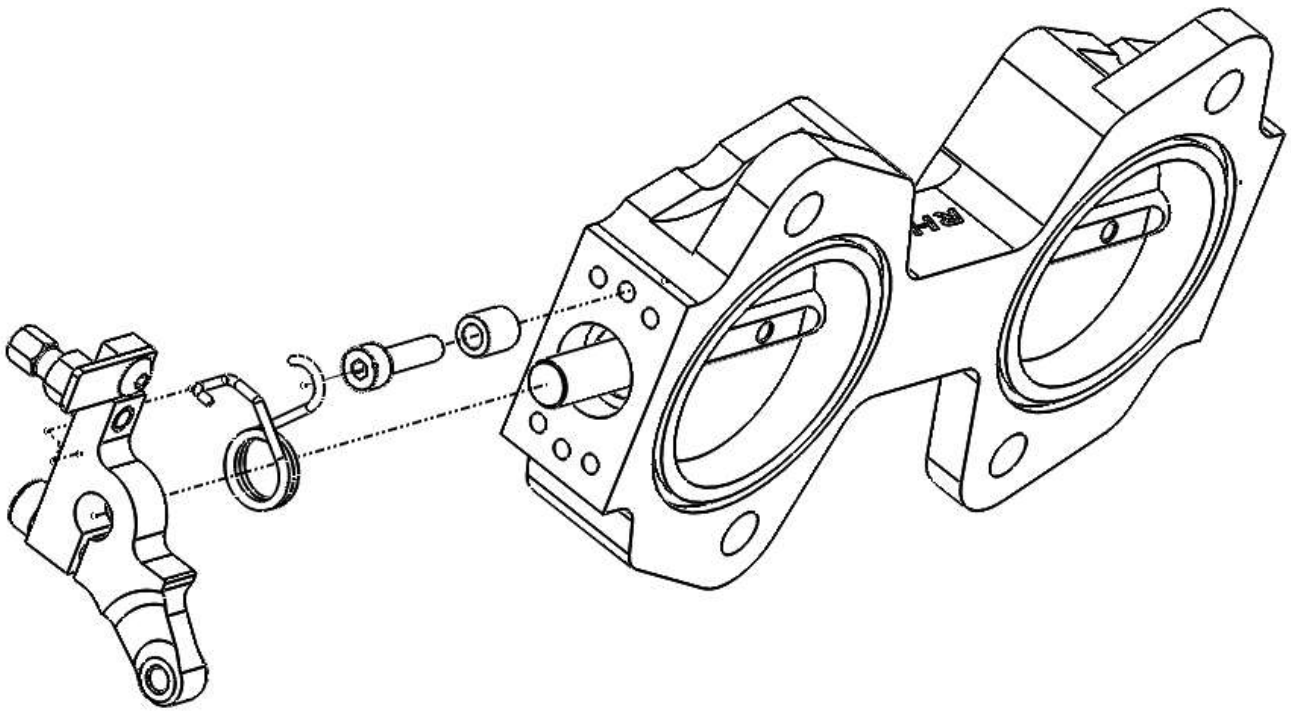

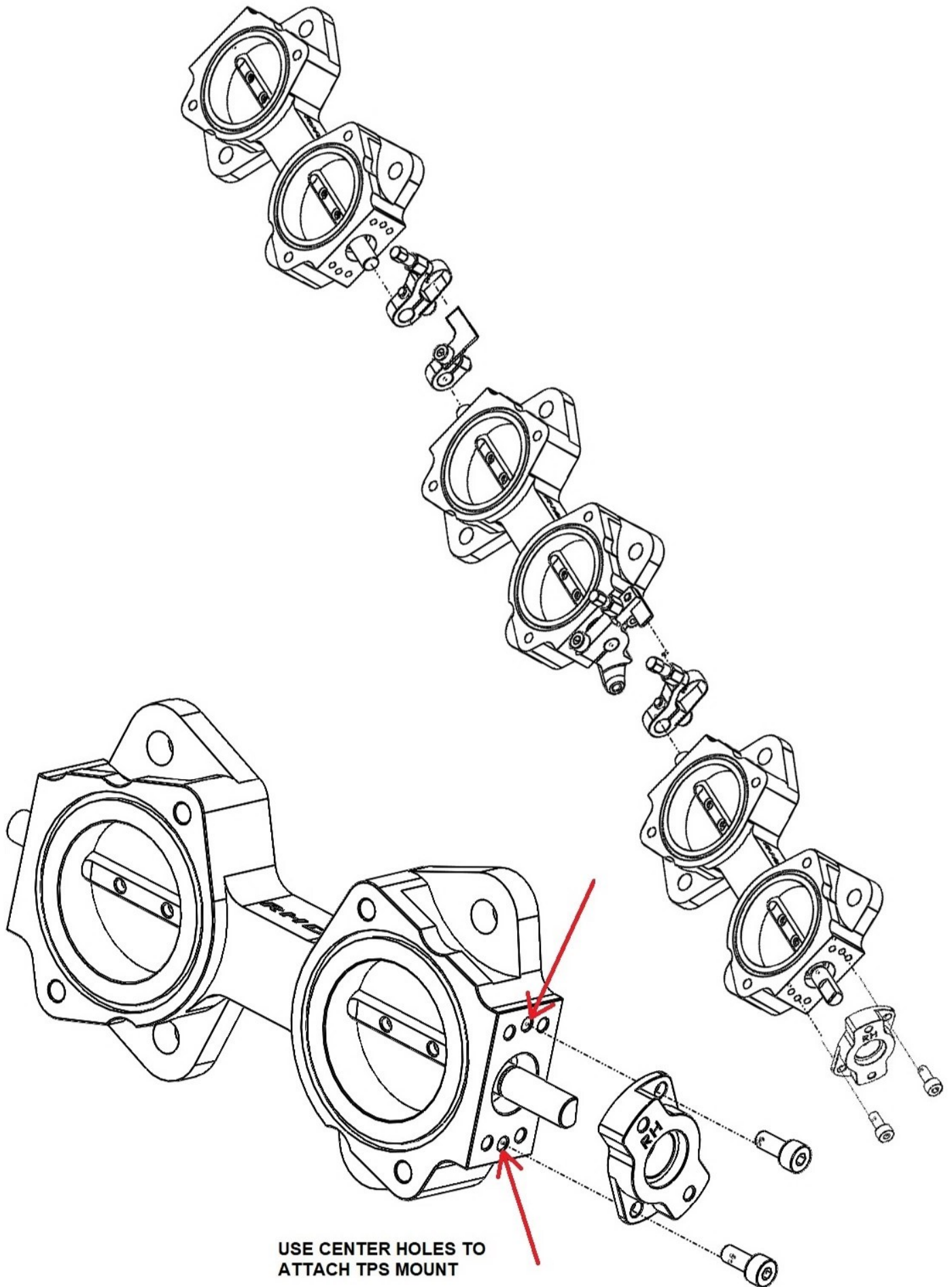

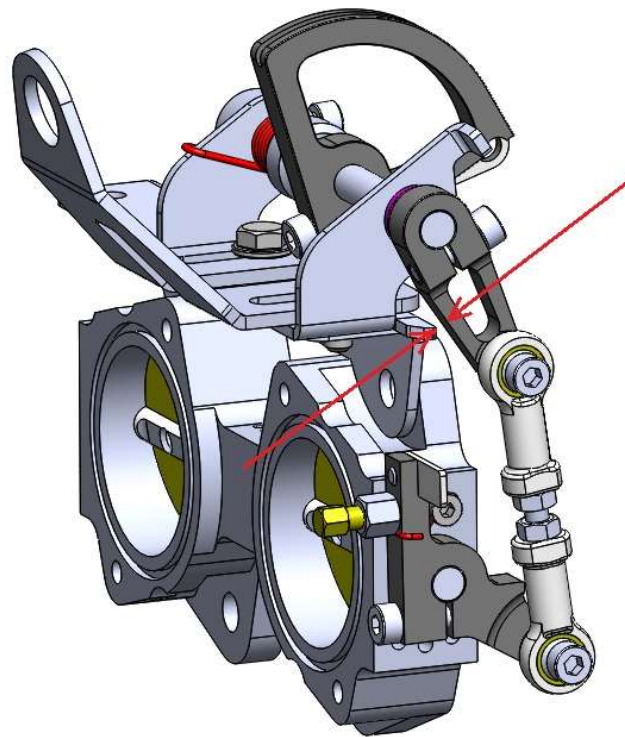
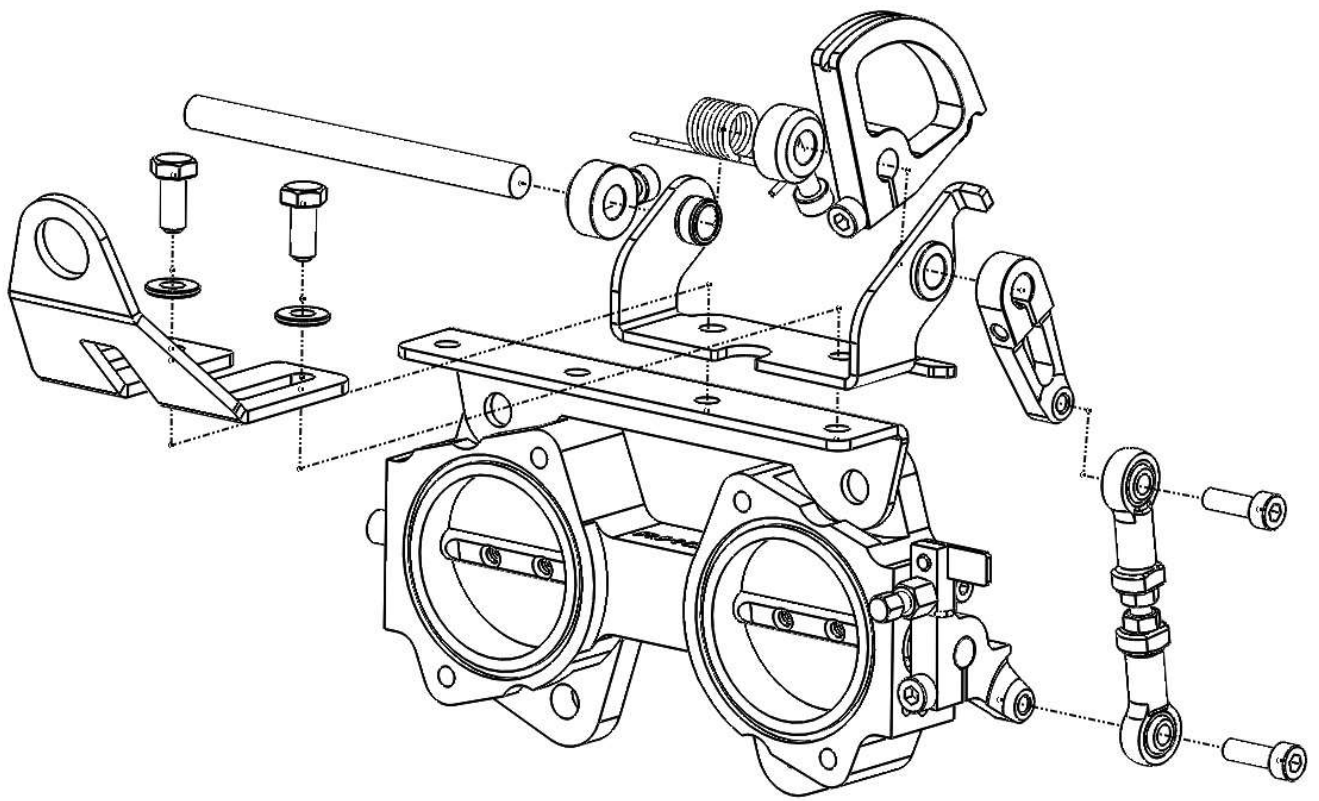

2-3mm Gap with throttle closed

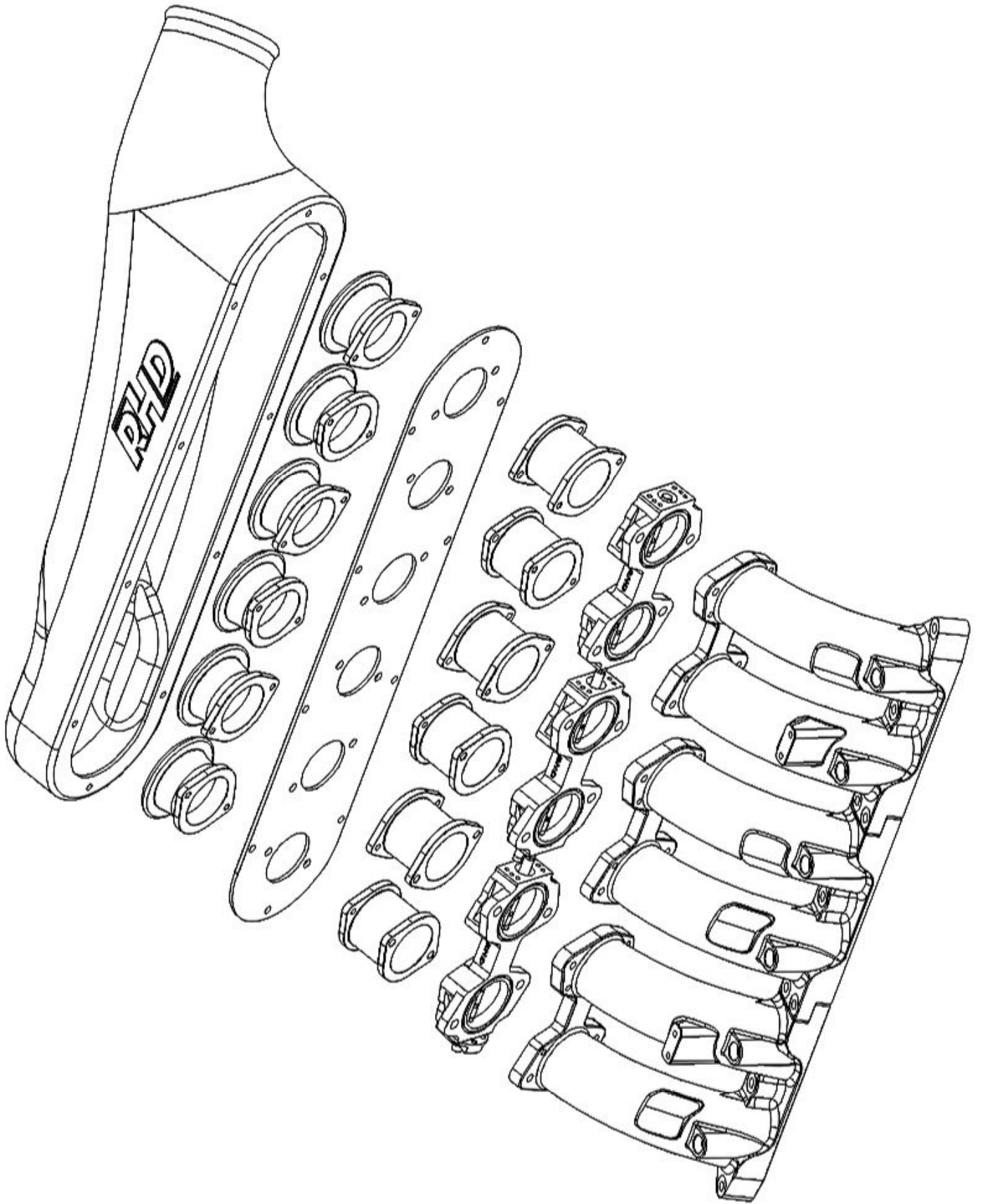

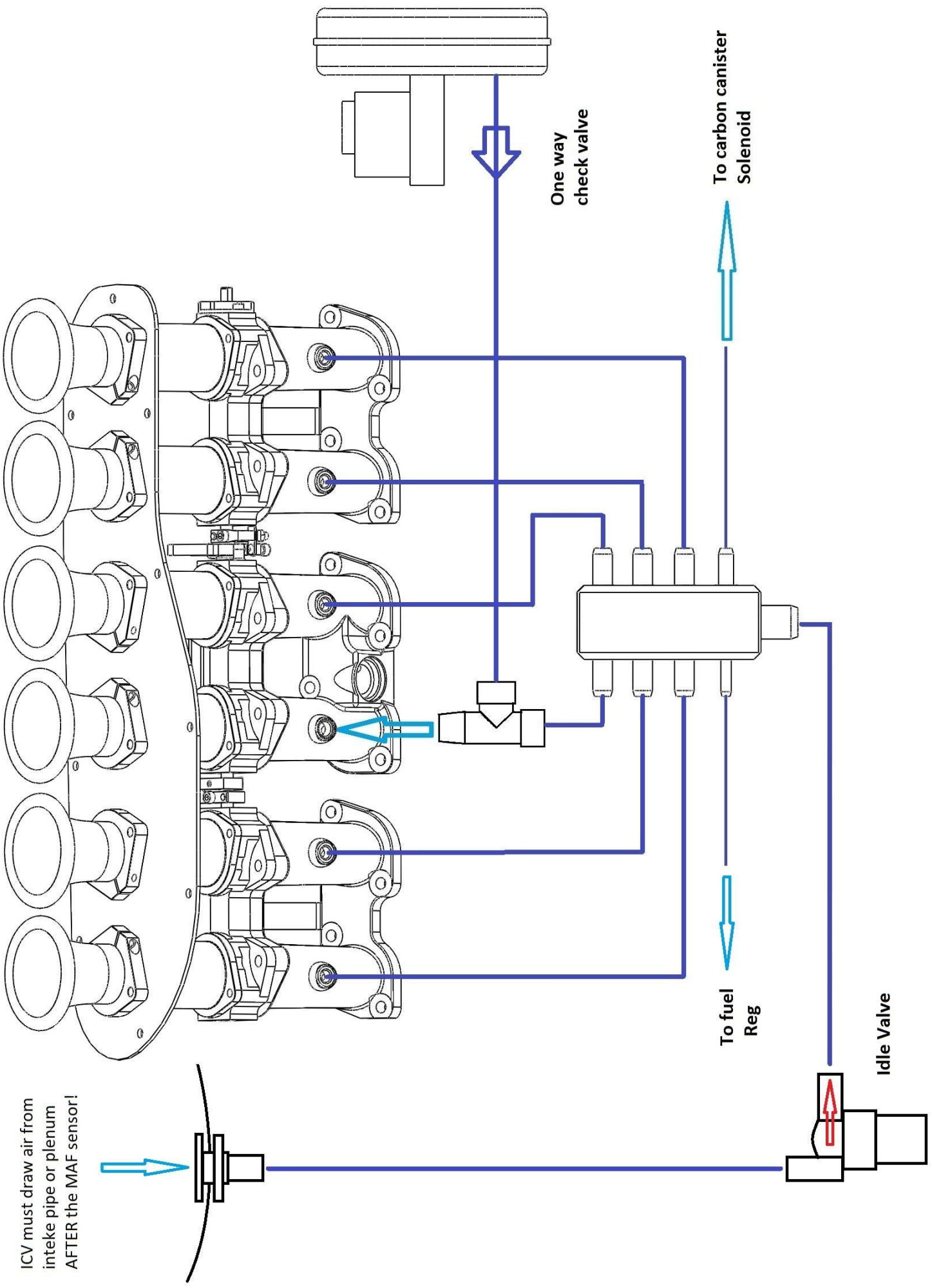

ICV must draw air from intake pipe or plenum AFTER the MAF sensor!

One way check valve

To carbon canister Solenoid

To fuel Reg

Idle Valve